

---

# SuperEvac<sup>®</sup> Vacuum Pump

---



## Operation and Maintenance Manual

Models 93511 - 93516  
93540 - 93598

# Table of Contents

Page

Features of your new pump.....3

The purpose of the SuperEvac™ design.....4

The 7 important steps of initial start-up.....5

Vacuum tips for best performance.....5, 6

Basic troubleshooting.....7

- Four most common problems
- Oil leakage
- The steps to solving 95% of all problems

Diagnostic chart.....8, 9

Replacement parts.....10, 11

Warranty and Service.....12

---

## Important Notices to Purchaser

Check for damage immediately.

Prior to shipment, all YELLOW JACKET® SuperEvac™ vacuum pumps are completely tested and inspected to assure compliance with Ritchie Engineering factory specifications.

If the pump carton is damaged, check contents immediately. Note damage on shipper's Bill of Lading and have shipper sign your statement. Notify the carrier immediately of the damage to arrange inspection of the pump and packaging.

The CARRIER ALONE is responsible for handling and settling your claim. Ritchie Engineering will cooperate in assessing damage if the pump is returned to the factory prepaid.

Carton contents include:

- SuperEvac pump
- Bottle of YELLOW JACKET SuperEvac Pump Oil
- Owner's manual
- Warranty registration card

To validate warranty, mail registration card within 10 days.

---

## Warning:

- This unit generates a deep vacuum that can be harmful to human tissue. Do not expose any part of the human body to the vacuum.
- Do not operate this unit with the exhaust blocked or restricted. Remove red shipping cap prior to use.
- Keep unit a minimum of 4" (10 cm) from objects to provide adequate cooling of motor.
- Continuous sound pressure level of this unit can exceed 70dB (A).
- Wear goggles and protective clothing when using this product.

## Features of your New Pump

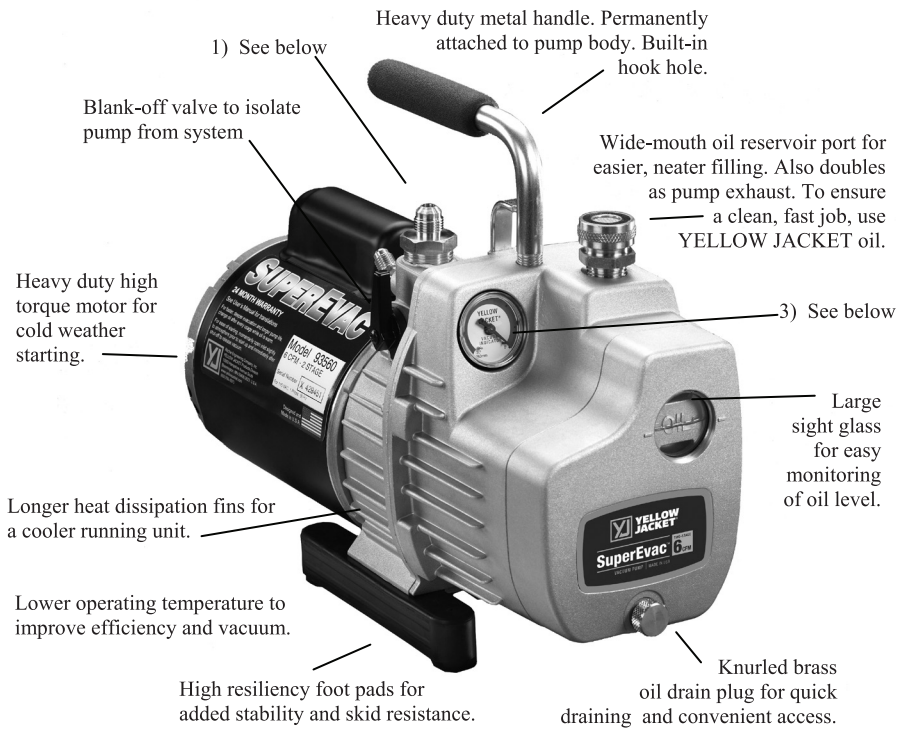

- 1) Male flare pump intake. Tethered cap stays with unit. Large diameter hose suggested for maximum pull down.
- 2) Additional 1/4" male flare port.
- 3) Vacuum gauge shows evacuation progress down to 30" range, so you'll know when to turn on electronic gauge for more precise reading.
- 4) Gas ballast valve (not shown) helps remove moisture and other condensable vapors that have been drawn into the pump as a result of evacuation.

Opening the ballast allows fresh air to enter the cartridge and keep vapors from combining with the oil. Vapors escape harmlessly through the exhaust valve. If combined with oil, vapors can turn the oil milky white and lower pump performance below specifications.

- 5) To operate ballast, turn the valve counter-clockwise one full turn after evacuation starts. As the vacuum reading reaches 1000-2000 microns, close the ballast to achieve a higher vacuum range.

# The Purpose of the SuperEvac™ Design

The SuperEvac™ Pump is a 2-stage rotary vane design (at right) that increases efficiency and speeds pump down to 15 microns.

The pump lowers the internal pressure of a refrigeration system until moisture boils into a vapor. As the moisture is vaporized, it is evacuated by the pump, helping dehydrate the system. Most technicians try to achieve between 250 and 1000 microns.

A manometer or electronic vacuum gauge are the only ways to monitor evacuation progress. Manometer readings are approximate in inches of mercury. Only an electronic vacuum gauge (see page 8) is accurate enough to show when you reach the desired micron range.

As the chart shows, only an electronic vacuum gauge reads fine differences to provide assurance that the vacuum is low enough to boil the greatest possible amount of moisture.

| Boiling temp of water | Inches mercury | Microns |
|-----------------------|----------------|---------|
| 212°F (100°C)         | 0              | 760,000 |
| 151°F (66°C)          | 22.05          | 200,000 |
| 101°F (38°C)          | 27.95          | 50,000  |
| 78°F (26°C)           | 28.95          | 25,000  |
| 35°F (2°C)            | 29.72          | 5,000   |
| 1°F (17°C)            | 29.882         | 1,000   |
| - 50°F (-46°C)        | 29.919         | 50      |

## How one small drop dampens your profits.

A small drop of moisture can hurt your profits and reputation.

During new system set-up, protective caps are removed admitting moisture and air into system components.

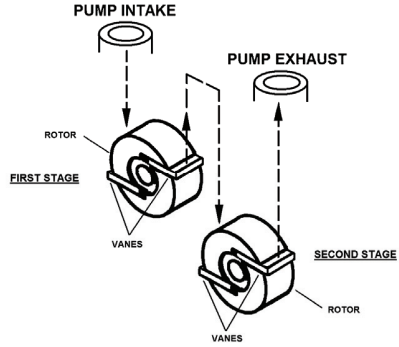

*First stage exhausts into the intake of the second stage similar to two single stage pumps connected together.*

If air – a non-condensable – remains in the system, it collects on the high side reducing system efficiency. This causes a rise in head pressure. The discharge valve gets hotter than normal and organic solids form causing compressor failure.

Moisture in the system can form ice which closes off openings in expansion valves and cap tubes, and prevent adequate cooling.

Ultimately moisture and air can produce acids and sludge which could cause in-warranty failures.

During service and parts replacement, the same contaminants get in again, and you could be called back for repairs by a dissatisfied customer.

Moisture and air can even enter through system leaks. And as the moisture in the air increases, so does the amount of contamination. The higher the humidity, the bigger your problem.

A vacuum pump "pulls" air and moisture out of the system before the system is damaged. The higher and more complete the vacuum, the more moisture is removed. That's why your SuperEvac pump is specifically engineered for high vacuums of 15 microns and better.

## The 7 Important Steps of Initial Start-Up

- 1) Make sure motor is off and name plate voltage on motor bottom matches outlet voltage.
- 2) Remove oil fill cap on pump cover. Fill with **YELLOW JACKET® SuperEvac™** Pump Oil until oil level is even with oil level line.
- 3) Make sure blank-off valve is in the open position (vertical). **Stay clear of the oil fill/exhaust port!** Remove intake cap to open intake to the atmosphere and then switch on the motor. When pump reaches running speed, replace cap. The vacuum indicator gauge should read 30 inches.
- 4) To check the pump's performance, attach a micron gauge to the 1/4" male flare fitting, making sure that the intake fitting is capped and the gas ballast valve is closed. Turn on the pump. The micron gauge will display the ultimate vacuum reached.
- 5) Improve cold weather starting by opening intake and running your pump for 10-15 seconds.
- 6) When turning pump off, open intake fitting until vacuum indicator gauge reads zero to break vacuum just prior to shut-off.
- 7) Disconnect pump and put cap on intake to keep out contaminants.
- 8) If an extension cord is needed, refer to the below chart for proper sizing:

**RECOMMENDED EXTENSION CORD SIZES**

| Total Extension Cord Length (Feet) |        |        |
|------------------------------------|--------|--------|
| 25'                                | 50'    | 100'   |
| 16 Ga.                             | 14 Ga. | 12 Ga. |
| Wire Gauge (AWG)                   |        |        |

## Vacuum Tips for Best Performance

### Quick tips:

- 1) For the fastest vacuum, connect your pump **directly** to the system. Going through a manifold slows the job.
- 2) Use as **large** a hose as possible, even though the system has 1/4" fittings. A 1/2" or 3/8" hose allows a much faster and more complete vacuum.
- 3) Use as **short** a hose as practical to get maximum evacuation speed. Short hoses make evacuation faster than longer hoses. Long hoses slow the process.
- 4) **Metal hoses** are the most impervious so will be most effective in evacuation.
- 5) Evacuate through **both high and low** sides at the same time to speed evacuation.
- 6) Use the **4-in-1 Vacuum/Charge Valve & Core Tool (Part #18975)** to remove the Schrader valves from the system and evacuate through unrestricted lines for a faster and higher vacuum. Removing Schraders saves over 30% in time.
- 7) Use **two pumps** on very large systems to reduce vacuum time. Put one of the pumps on the low side of the system.



- 8) Use a SuperEvac System I, II or III to decrease vacuum time by over 50%. These systems include a 2-valve vacuum manifold and two 3/8" vacuum hoses which can evacuate three times faster than a 1/4" hose.



- 9) Use a heat gun on the condenser and evaporator to speed the evacuation process.

**Built-in vacuum gauge:** The unique built-in indicator gauge in you pump monitors evacuation progress down to the 29-30" range. If the reading stays in the mid range, there is either high contamination or a large leak in the system.



Gross Leak

If you think there is excessive moisture, blow out the AC&R system with dry nitrogen wherever possible. This reduces the amount of contaminants that must be "pulled" into the pump and increases evacuation speed.

Use a nitrogen regulator valve with pressure limited to 150 psi, and a frangible disc device set at 175 PSIG.

When the indicator reaches the 29-30" range, turn on the electronic micron gauge for more precise readings.



Turn on electronic gauge

**Oil Changes: CHANGE OIL AFTER EACH USAGE** to protect pump components from contaminants pulled into pump during service. Place used oil in a sealable container and dispose properly in accordance with local regulations.

## Dual Voltage Motor Power Conversion (if applicable)

### STEP 1

Disconnect the motor from the power supply and remove. Remove the yellow "CAUTION" sticker from the back of the motor.

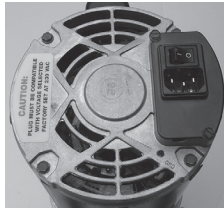

### STEP 2

Pull up on the white plastic "arrow" switch using needle-nosed pliers until the switch is loose inside the motor housing (it will not come completely out of the motor).



Note: Do not try to turn or rotate the switch until it has been pulled up and is loose.

### STEP 3

Point the arrow toward the desired voltage setting and push the switch back down into the motor. The arrow on the switch should be sub-flush of the motor housing when correctly installed at the desired voltage.



HI = 230 VAC / 50 Hz  
LO = 115 VAC / 60 Hz

### STEP 4

Replace the yellow "CAUTION" sticker over the voltage selector switch.

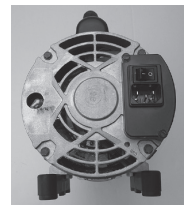

Ensure that the voltage setting corresponds with the power supply that the motor is plugged into.

# Basic Troubleshooting

## 4 most common comments on pump return paperwork

- 1) **"Will not pump"** This usually means the pump will not pull a high enough vacuum. This can be caused by valve being left open, missing "O"-rings under caps or contaminated oil.

SUGGESTION: Change valve and "O"-rings change oil twice and recheck vacuum.

- 2) **"Will not pull below 1000 microns."**

SUGGESTION: Check for "O"-rings. Test pump to determine actual pull down. Remove all hoses and connect vacuum sensor directly to pump.

- 3) **"Noisy."** Pumps are noisy when they have not achieved a high vacuum. In intermediate vacuum, there will be oil, vane and exhaust noises.

SUGGESTION: Listen to the pump at high vacuum. If relatively quiet, the pump is running properly. If still noisy, there may be a system leak.

- 4) **"Repair and return."** This is the most difficult return comment to handle, since we are unsure of what needs to be done to keep the customer satisfied.

SUGGESTION: Be specific about the problem with your pump if returning it.

## Starting problems

- Be sure pump is plugged into live receptacle with line voltage plus or minus 10% of voltage on motor nameplate. Long extension cords can greatly reduce voltage and cause problems.
- Pump/oil temp. must be 30°F (-1°C) or higher. Open intake to atmosphere and switch on pump; run up to speed before connecting to system.

- Your SuperEvac™ pump features a heavy-duty high torque motor for cold weather starting, but dirty oil makes starting more difficult, causing unnecessary wear on your unit.
- Dropping your pump can damage it. In a locked pump condition, motor will not run and the thermal overload will kick out.
- Disconnect power cord and set pump with front cover face down on table. Reach into coupling area and try to rotate the coupling. Do not use pliers. If the pump does not rotate, it is "locked up."

## Oil leakage

- If leak develops between front and rear half of oil case, tighten all seven screws. Replace gasket if necessary.
- If shaft seal leaks, replace it.
- Wipe pump dry and watch for source of leak. Tighten screws and repair.

## The steps to solving 95% of all problems

- 1) **Check oil level when pump is running.** It should be 1/2 to 5/8 up in the sight glass, the level necessary for proper operation.
- 2) **Check vacuum pump.** Connect micron gauge directly to the 1/4" port and cap intake port. Turn on pump, open the valve and check vacuum reading. If reading is good, check the system for leaks. OR, if testing a system, isolate pump with blank-off valve and get vacuum reading from the pump alone. If the pump does not pull and stay at a good vacuum level, run until hot and change oil.
- 3) **Check all flare connections.** Make sure they are tight.

## SuperEvac™ LCD Digital Vacuum Gauge



This portable, lightweight, solid state instrument indicates the vacuum pressure in the system using thermocouple technology. This is important because you need to know the vacuum to confirm moisture removal. The battery powered gauge measures atmospheric pressures of 760,000 to 1 micron in easy to read 1/2" high numbers (**Part #69075**).

### Diagnostics Chart

| Condition   | Pump Area   | Possible Problem   | Solution  |
|-------------|---|--|---|
| Poor vacuum | Quiet pump  | Dirty oil<br>Drive coupling or set screw loose<br>Bent or broken exhaust valve<br>Pump not oiling<br>Vanes not functioning               | Flush 1 to 3 times<br>Repair or replace<br>Repair or replace<br>Call factory<br>Call factory  |
|             | Ultimate of pump - does not need mfg. spec (read with thermocouple) | Pump dropped<br>Micron gauge malfunction<br>Poor motor performance<br>Dirty oil<br>Air leaks<br>System leaks<br>Fitting sealant compound | Call factory<br>Verify with second gauge<br>Repair or replace<br>Flush 1 to 3 times<br>Repair or replace<br>Isolate/repair<br>Repair or replace |
| Oil Leaks   | Exhaust   | Oil level high<br>System vented pressure through pump<br>Pump tipped over  | Adjust oil level<br>Check oil level, add or replace oil<br>Check oil level, add or replace oil  |
|             | Seal  | Worn or damaged seal<br>Motor loose  | Replace<br>Adjust/tighten, check seal   |
|             | Case  | Gasket bolts loose<br>Oil drain fitting<br>Gasket damaged  | Tighten<br>Repair or replace<br>Replace   |



| Condition        | Pump Area                 | Possible Problem   | Solution   |
|------------------|---------------------------|--|--|
| Pump won't start | Motor stalled<br>hot/cold | Damaged motor<br>Damaged pump<br>Closed intake/gas ballast on pumps  | Repair or replace<br>Replace/call factory<br>Open intake fitting and gas ballast.  |
|                  | Thermal                   | Low voltage<br>Cold weather cut-out<br><br>Dirty oil   | Shorter extension cord<br>Open intake fitting for 10-15 sec. to warm up while starting.<br>Flush 1 to 3 times                            |
| Unusually noisy  | Motor areas               | Worn motor<br>Loose motor bolts<br>Drive coupling  | Replace motor<br>Tighten bolts<br>Adjust/replace coupling  |
|                  | Pump cartridge            | Dirt, low, improper oil<br>Air leaks:<br>1) caps/connection<br>2) Gaskets/"O"-rings<br>3) Fittings<br>4) System leak | Flush and replace oil<br><br>Tighten<br>Replace/put on oil<br>Replace/reseal<br>Isolate pump with blank-off valve and repair system leak |
| High temp        | Motor                     | Low voltage  | Short extension cord   |
|                  | Pump                      | Dirty oil<br>Low oil<br>Lint/foreign material<br>Parts friction<br>Too small for system<br>Air leaks                 | Flush and replace<br>Add/replace<br>Open gas ballast<br>Replace oil/call factory<br>Size pump for system<br>Replace/repair               |
| Poor vacuum      | Noisy pump                | System leaks<br>Low oil level<br>Dirty oil<br>Worn pump<br>Air leaks and fittings or gasket seals                    | Repair leaks<br>Add/replace<br>Flush 1 to 3 times<br>Replace module, call factory<br>Replace/repair                                      |

# Replacement Parts

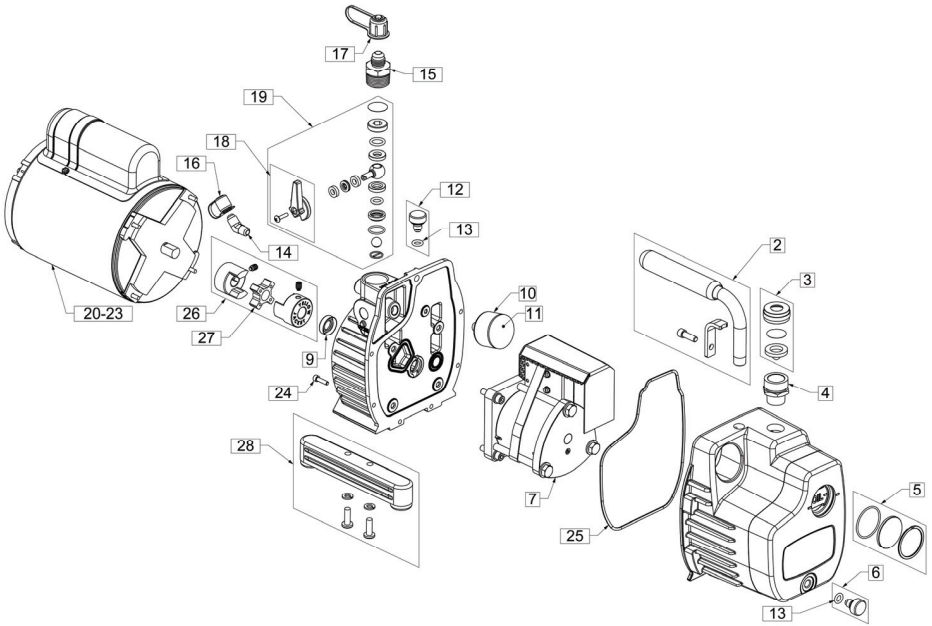

|   | <b>Pump #</b><br>93514<br>93516<br>93594<br>9354x | <b>Pump #</b><br>93515<br>93596<br>9356x | <b>Pump #</b><br>93511<br>9358x | <b>Pump #</b><br>93590<br>93592<br>93593<br>93595<br>93598 |
|---|---|--|---------------------------------|--|
|   | <b>4 CFM</b>                                      | <b>6 CFM</b>                             | <b>8 CFM</b>                    | <b>11 CFM</b>  |
|   | <b>(113 L/M)</b>                                  | <b>(170 L/M)</b>                         | <b>(227 L/M)</b>                | <b>(311 L/M)</b>   |
| <b>Pump oil cover</b>                             |   |  |                                 |  |
| 1. Complete cover (individual parts listed below) | 93501   | 93502                                    | 93503                           | 93504  |
| 2. Handle with screw                              | 93370   | 93370                                    | 93370                           | 93370  |
| 3. Oil fill cap and seal                          | 93390   | 93390                                    | 93390                           | 93390  |
| 4. Oil fill fitting                               | 93391   | 93391                                    | 93391                           | 93391  |
| 5. Oil sight glass                                | 93365   | 93365                                    | 93365                           | 93365  |
| 6. Oil drain                                      | 93368   | 93368                                    | 93368                           | 93368  |
| <b>Vacuum cartridge</b>                           |   |  |                                 |  |
| 7. Complete cartridge with oil cover gasket       | 93541   | 93561                                    | 93581                           | 93591  |

|   | <b>Pump #<br/>93514<br/>93516<br/>93594<br/>9354x</b> | <b>Pump #<br/>93515<br/>93596<br/>9356x</b> | <b>Pump #<br/>93511<br/>9358x</b> | <b>Pump #<br/>93590<br/>93592<br/>93593<br/>93595<br/>93598</b> |
|---|---|---|-----------------------------------|---|
|   | <b>4 CFM</b>  | <b>6 CFM</b>                                | <b>8 CFM</b>                      | <b>11 CFM</b>   |
|   | <b>(113 L/M)</b>                                      | <b>(170 L/M)</b>                            | <b>(227 L/M)</b>                  | <b>(311 L/M)</b>  |
| <b>Mounting body</b>  |   |   |                                   |   |
| 8. Complete body (individual parts below)   | 93500   | 93500                                       | 93500                             | 93500   |
| 9. Shaft seal   | 93031   | 93031                                       | 93031                             | 93031   |
| 10. 30" vacuum gauge  | 93011   | 93011                                       | 93011                             | 93011   |
| 11. Vacuum gauge crystal  | 93012   | 93012                                       | 93012                             | 93012   |
| 12. Gas ballast with "O"-ring   | 93368   | 93368                                       | 93368                             | 93368   |
| 13. "O"-ring for gas ballast/drain plug   | 93398   | 93398                                       | 93398                             | 93398   |
| 14. 1/4" elbow fitting  | 93028   | 93028                                       | 93028                             | 93028   |
| 15. Intake fittings   | 93377 (3/8")<br>40265 (Acme)                          | 93377 (3/8")<br>40265 (Acme)                | 93393 (1/2")<br>40265 (Acme)      | 93393 (1/2")<br>40265 (Acme)                                    |
| 16. Intake cap (1/4")   | 93394   | 93394                                       | 93394                             | 93394   |
| 17. Flare caps  | 93399 (3/8")<br>40284 (Acme)                          | 93399 (3/8")<br>40284 (Acme)                | 93395 (1/2")<br>40284 (Acme)      | 93395 (1/2")<br>40284 (Acme)                                    |
| 18. Blank-off valve with handle   | 93366   | 93366                                       | 93366                             | 93366   |
| 19. Complete parts for blank-off handle   | 93367   | 93367                                       | 93367                             | 93367   |
| <b>Motor</b>  |   |   |                                   |   |
| 20a. 1/2 hp - 115V / 60 Hz<br>(includes items 21, 22, 23a below)                                      | 93505   | 93505                                       | 93505                             | 93505   |
| 20b. Export models: 1/2 hp - dual voltage<br>115V / 60 Hz, 230V / 50 Hz<br>(includes items 21 and 22) | 93513   | 93513                                       | 93513                             | 93513   |
| 21. 8/32 x 7-1/4" motor bolts (4)   | 93099   | 93099                                       | 93099                             | 93099   |
| 22. Rocker style switch   | 93117   | 93117                                       | 93117                             | 93117   |
| 23a. 8' long US cord  | 93115   | 93115                                       | 93115                             | 93115   |
| 23b. 8' long EU cord (detachable IEC-320)   | 95431   | 95431                                       | 95431                             | 95431   |
| 23c. 8' long UK cord (detachable IEC-320)   | 95432   | 95432                                       | 95432                             | 95432   |
| <b>Final assembly parts</b>   |   |   |                                   |   |
| 24. 8/32 x 5/8" socket head screws  | 93506   | 93506                                       | 93506                             | 93506   |
| 25. Oil cover gasket  | 93507   | 93507                                       | 93507                             | 93507   |
| 26. Drive coupling  | 93047   | 93047                                       | 93047                             | 93047   |
| 27. Coupling spider   | 93050   | 93050                                       | 93050                             | 93050   |
| 28. Right or left leg assembly with screws  | 93034   | 93034                                       | 93034                             | 93034   |

Damaged supply cords must be replaced by special assemblies available from the manufacturer or its distributors.

| <b>9354x</b>        | <b>9356x</b>        | <b>9358x</b>        | <b>9359x</b>        |
|---------------------|---------------------|---------------------|---------------------|
| 28.3 lbs. (12.8 kg) | 29.0 lbs. (13.1 kg) | 30.3 lbs. (13.7 kg) | 31.5 lbs. (14.3 kg) |

# WARRANTY INFORMATION

Ritchie Engineering guarantees YELLOW JACKET® products to be free of defective material and workmanship which could affect the life of the product when used for the purpose for which it was designed. This warranty does not cover items that have been altered, abused (including failure to use the correct type of vacuum pump oil) or returned solely in need of field service maintenance.

If found defective, we will either replace or repair at our option products within warranty period. Returns must be pre-paid.

Warranty does not cover use of lithium bromide, ammonia or leak stop type products.

See [www.yellowjacket.com](http://www.yellowjacket.com) or contact customer service for full warranty details.

## How to Obtain Service

Most returned pumps are merely in need of normal field service maintenance, such as changing oil or making minor adjustments. In many instances, the troubleshooting information in this manual can save you the time and effort of returning your pump. When the information contained in this manual, however, does not solve the problem, please call for service.

Call the Ritchie Engineering Customer Service Department:

Phone: (952) 943-1333 or  
(800) 769-8370

Fax: (952) 943-1605 or  
(833) 322-8684

E-mail: [custserv@yellowjacket.com](mailto:custserv@yellowjacket.com)

You will receive personal help in determining if the problem can be solved without sending your pump to the factory and taking it out of service.



Ritchie Engineering Co., Inc.  
YELLOW JACKET Products Division  
10950 Hampshire Ave., S.  
Bloomington, MN 55438-2623 USA  
e-mail: [custserv@yellowjacket.com](mailto:custserv@yellowjacket.com)  
Web Site: [www.yellowjacket.com](http://www.yellowjacket.com)

Phone: 800-769-8370  
Int'l Phone: 952-943-1333  
Fax: 800-322-8684  
Int'l Fax: 952-943-1605