

Leak Monitors



YELLOW JACKET®

Installation & Operation*



Content	Page
1- Installation Instructions	
2- Location Instructions	
3- Typical Settings	
4- Operating Instructions	
5- Test/Function Instructions	
6- Decorative Remote Sensor Installation	
7- Annual Test	
8- Check/Calibration Procedure	
9- Troubleshooting	
10- Installation and Wiring Diagrams	
11- Mounting Diagrams	



*Technician use only

This unit must be installed by a suitably qualified technician who will install this unit in accordance with these instructions and the standards set down in their particular industry/country. Suitably qualified operators of the unit should be aware of the regulations and standards set down by their industry/country for the operation of this unit. These notes are only intended as a guide and the manufacturer bears no responsibility for the installation or operation of this unit.

Failure to install and operate the unit in accordance with these instructions and with industry guidelines may cause serious injury including death and the manufacturer will not be held responsible in this regard.

1- Installation Instructions

The main alarm unit and its sensor(s) should be positioned carefully to avoid mechanical damage (from moving machinery, doors, etc.) thermal extremes (close to heaters) and should not be placed unprotected in direct strong drafts/airflows and areas where water or moisture is present unless an appropriate enclosure is used.

Avoid routing sensor cabling outside of premises, or between buildings via overhead cables. Also, sensor wiring should be kept a minimum of **500mm** from mains and telephone cables. (See section on sensor location)

When connecting the mains and / or sensor cables ensure a second mechanical fixing is used. Use a cable tie inside the enclosure within **25mm** of the cable gland.

When power to the unit is switched on, there is a 3-minute delay before the system activates. This allows the sensors to warm up to the correct temperature for gas detection. The green light on the alarm panel comes on after the delay, indicating that the system is ready. When a unit has been off or stored for a long time the normalising period may be longer than 3 minutes. After the 3 minutes has expired alarms may activate. You may deactivate the siren until normalisation is complete. (Key switch).

1.1 Remove the front cover. Mount the control unit using the mounting holes in the base such that the sensor cable terminal blocks are at the bottom of the unit in a convenient position (observing the above note).

1.2 Wiring to Remote Sensors:

Connect sensor cable (standard 4 wire alarm cable as specified below) to sensor terminal block CN1 on control unit positions 1,2,3 & 4. Route cable through the gland to remote sensor No.1.

Standard Sensors:

Remove lid of sensor. (To open the sensor enclosure : turn the cable gland ½ turn counterclockwise to loosen the internal nut, depress the clip on top of the enclosure and open). Connect the other end of the sensor cable to terminal block CN1 positions 1,2,3 & 4. Mount sensor box. Replace lid. Repeat above sequence for remaining sensors (depending on supplied system configuration.) Feed the cable through the bottom of the sensor enclosure.

Please ensure that connections 1 to 4 on the sensor connect to their corresponding numbers on the terminal block in the main alarm unit, otherwise the system will not function correctly.

Maximum Sensor Wiring Length: 230V Systems	
1 - 2 Channel Standard Units:	40 Metres 7/0.2mm Alarm Cable (Max. 3.52 Ohms / Core)
4 - 6 Channel Standard Units:	100 Metres 7/0.2mm Alarm Cable (Max. 8.8 Ohms / Core)

Maximum Sensor Wiring Length: 120V Systems	
1 - 2 Channel Units:	60.9M (200 feet) 22 gauge, stranded 4 wire Alarm Cable (Max 3.52 Ohms/Wire)
4 - 6 Channel Units:	152.25 Metres (500 feet) 22 gauge, stranded 4 wire Alarm Cable (Max 8.8 Ohms/Wire)

You may use different cables and longer distances provided the ohmic resistance shown is not exceeded.

1.3 External Sounder and uncommitted 12 Volt DC output.
(Applies to 4 - 6 Channel systems only)

12 volt DC Sounder (12V /150MA max) - connect positive lead to CN11 terminal marked '+12V', negative to centre terminal marked 'BUZZ'.

For uncommitted 12 V DC @100mA output is obtained via CN11 Terminals '+12V' and '0V' This output may be wired via the volt free relays to obtain a switching 12 volt DC output to drive an external relay or solenoid as follows:

If both the buzzer and 12V DC output are corrected correctly they should not exceed, 250MA in total.

Connect Terminal '+12V' on CN11 to the 'COM' terminal of the volt free

relay, and the device to be switched to either the N/O or N/C Terminals of the volt free relay, depending on whether a 12 Volt output is required during an alarm condition or while the system is on standby. The return from the device is connected to OV on CN11

1.4. Voltage Free Relays.

10A @ 120/230 VAC

	Two Level Unit:	One Level Unit:
1 & 2 Channel Systems:	CN5: Low Level Alarm CN4: High Level Alarm	CN4
4 - 6 Channel Systems:	CN10: Low Level Alarm CN9: High Level Alarm CN12: Fault Reporting Relays	CN10

Notes: N/O and N/C refer to contact status in standby mode.
On a two level system, A high level alarm condition on any sensor will override a low level alarm condition on another sensor.

On 4 - 6 Channel two level units, the high level relay may be set for normal or Fail-Safe operation by setting jumper JP1 on the control unit printed circuit board (Refer to Installation diagram)

Connect leads to terminal block for Common (COM) and N/O and/or N/C connections as required.

1.5. Mains Connection.

Connect mains supply (using 3-core 0.75 mm, Mains Flex for 230V systems or 3 wire, 18 gauge 0.823mm sq mains flex for 120V Systems) to terminal block CN3 (on 1 & 2 channel systems), or fused terminal block mounted on base of control unit (4 - 6 channel systems), Connections L, N and E. Ensure that earth connections to the lid and base of the enclosure are maintained.

NOTE: Connection to mains supply must be via an approved readily accessible, switched and fused (2 or 5 Amp Fuse) plug and socket or as per local wiring regulations which should be within 3 meters (10 feet) of the control unit.

- The mains cable used should be of an approved type HAR or Cenelec approved or locally approved equivalent.
- If replacement of the mains fuse is required use only the appropriate type from the table below

Control Unit Type:	Fuse Rating	Sensor Connection	Siren /
230V Systems	Main Supply	Fuse:	Auxiliary
1 - 2 Channel Unit:	20mm T50mA	Not Applicable	Not Applicable
	230V Fuse		
4 - 6 Channel Unit:	20mm T160mA	20mm T250 mA	20mm T315 mA
	230V Fuse	230V Fuse	230V Fuse

Control Unit Type:	Fuse Rating	Sensor Connection	Siren /
120V Systems	Main Supply	Fuse:	Auxiliary
1 - 2 Channel Unit:	20mm T100mA	Not Applicable	Not Applicable
	120V Fuse		
4 - 6 Channel Unit:	20mm T315mA	20mm T250 mA	20mm T315 mA
	230V Fuse	120V Fuse	230V Fuse

- The blanking plugs for cable entries should only be removed if being replaced by cable glands
- Ensure that the live and neutral conductors take the strain before the earth conductor.

2. Location Instructions

Location of Sensors

Sensors must be located within the appropriate wire lengths from the central control unit.

In all cases the sensor supplied is designed for maximum sensitivity to a particular gas.

However, in certain circumstances false alarms may be caused by the occasional presence of sufficiently high concentrations of other gaseous impurities. If such a situation is likely to arise installers should check with our Technical Department so that sensor (s) of suitable cross sensitivity can be supplied. Examples of situations where such abnormalities may arise include.

- Plant room maintenance activity involving solvent or paint fumes or refrigerant leaks.

- Plant rooms in fruit ripening/storage facilities because of accidental gas migration (bananas - ethylene, apples - carbon dioxide)
- Heavy localised exhaust fumes (carbon monoxide, dioxide, propane) from engine driven forklifts in confined spaces or close to sensors.

A response delay is built in to the system to minimise the possibilities of false alarms.

Machinery rooms

There is NO ABSOLUTE RULE in determining the number of sensors and their location. However a number of simple guidelines will help to make a decision. Sensors monitor a point as opposed to an area. If the gas leak does not reach the sensor then no alarm will be raised. Therefore, it is extremely important to carefully select the sensor location. Also consider ease of access for maintenance.

The size and nature of the site will help to decide which method is the most appropriate to use. Locations requiring the most protection in a machinery or plant room would be around compressors, pressurised storage vessels, refrigerant cylinders or storage rooms or pipelines. Most vulnerable are valves, gauges, flanges, joints (brazed or mechanical), filling or draining connections etc

When mechanical or natural ventilation is present mount a sensor in the airflow. In machinery rooms where there is no discernable or strong airflow then options are:

- Point Detection, where sensors are located as near as possible to the most likely sources of leakage, such as the compressor, expansion valves, mechanical joints or cable duct trenches.
- Perimeter Detection, where sensors completely surround the area or equipment.
- With heavier than air gases such as halocarbon and hydrocarbon refrigerants such as R404A, propane, and butane sensors should be located near ground level
- With lighter than air gas e.g. ammonia, the sensor needs to be located above the equipment to be monitored e.g. on a bracket or high on a wall within 300 mm of, or on the ceiling provided there is no possibility of a thermal layer trapped under the ceiling preventing gas reaching the sensor. (NB. At very low temperatures, such as in a refrigerated cold store, ammonia gas becomes heavier than air).
- With similar density or miscible gases, such as CO or CO₂, sensors should be mounted about head high – say 1.5m.
- Sensors should be positioned a little way back from any high-pressure parts to allow gas clouds to form. Otherwise any leakage of gas is likely to pass by in a high-speed jet and not be detected by the sensor.
- Make sure that pits, stairwells and trenches are monitored since they may fill with stagnant pockets of gas.
- If a pressure relief vent pipe is fitted to the system, it may be a requirement to mount a sensor to monitor this vent pipe. It should be positioned about 2 m above the PRV to allow gas clouds to form.
- With racks or chillers pre-fitted with refrigerant sensors, these should be mounted so as to monitor the compressors or if extract ducts are fitted the airflow in the duct may be monitored.

Refrigerated Spaces

In refrigerated spaces sensors should be located in the return airflow to the evaporators on a sidewall, below head high preferred, or on the ceiling, **not** directly in front of an evaporator. In large rooms with multiple evaporators, sensors should be mounted on the central line between 2 adjacent evaporators, as turbulence will result in airflows mixing.

Chillers

In the case of small water or air-cooled enclosed chiller units mount the sensor so as to monitor airflow to the extract fans. With larger models also place a sensor inside the enclosure under or adjacent to the compressors

In the case of outdoor units:

- such as enclosed air-cooled chillers or the outdoor unit for VRV/VRF systems mount the sensor so as to monitor airflow to the extract fan. With large units also place a sensor inside the enclosure under or adjacent to the compressors

In the case of non-enclosed outdoor units

- If there is an enclosed machinery section then locate a sensor there.
- In the case of units with enclosed compressors, mount sensors in the enclosures
- Where you have protective or acoustic panels mount the sensor low down under the compressors where it is protected by the panels.

- With air-cooled chillers or air-cooled condensers with non-enclosed condenser sections it is difficult to effectively monitor leaks in the coil sections. With some designs it will be possible using an airflow sensor to monitor airflow to the start –up fans in the front or rear sections.
- If there is a possibility of refrigerant leaks into a duct or air-handling unit install a sensor to monitor the airflow.

Weatherproof sensors should be used for unprotected outdoor applications.

Air Conditioning – Direct systems VRV/VRF

EN378 states that at least one detector shall be installed in each occupied space being considered and the location of detectors shall be chosen in relation to the refrigerant and they shall be located where the refrigerant from the leak will collect. In this case refrigerants are heavier than air and detectors should have their sensors mounted low .e.g. at less than bed height in the case of an hotel or other similar Category Class A spaces. Ceiling or other voids if not sealed are part of the occupied space.



In a hotel room monitoring in ceiling voids would not strictly comply with EN378

Do's

Don'ts

- mount the in-room sensor at less than the normal heights of the occupants e.g in a hotel room this is less than bed height - between 200-500mm off the floor.
- away from draughts and heat sources like radiators etc.
- avoid sources of steam
- Do not mount sensors
 - under mirrors
 - at vanity units
 - in or near bathrooms

For further detailed Installation tips covering most installations and equipment types.. chillers, air cooled chillers etc see our web site www.murco.ie.

Perhaps the most important point of all is not to try and economise by using the minimum number of sensors possible. A few extra sensors could make all the difference if a gas leak occurs!

3- Typical settings

Gas: Refrigerant R404A **Low Alarm Set Point:** 100ppm
High Alarm set Point: 1000 ppm

For a particular unit please refer to the gas settings shown on the rating plate.

4- Operating Instructions

The YELLOW JACKET Gas Monitor having been installed in accordance with the installation instructions is ready to monitor the chosen air space and detect gas leaks at the pre-set level.

Each of the sensors has a green light to indicate that power is present.

To minimise false alarms, the system has a built in delay, between the arrival of gas at the sensor unit, and an alarm occurring. This delay is 20-25 seconds before a low level alarm, and 25-30 seconds on a high level alarm.

Unit Operation

Idle: Only the green light on the panel is on. No gas is present.

If the green light is off, power to the unit has been interrupted. Refer to the troubleshooting guide.

Alarm Condition

Low Alarm: One of more yellow lights on the panel turn on. The sounder operates intermittently, and the low alarm volt free relay operates: this indicates presence of a low level of gas on one or more sensors.

High Alarm: One of more red lights on the panel turn on. The sounder operates continuously, and the high alarm volt free relay operates: this indicates presence of a high level of gas on one or more sensors.

For the purpose of system maintenance, the siren may be disabled temporarily by using the key-switch.

Low-level alarm conditions will reset automatically when the gas dissipates. High level alarm conditions require a manual reset (By pressing the reset button) Please note that a high alarm condition can only be reset 30-60 seconds after the gas clears from around the sensors.

5- Test / Function Instructions

The unit is calibrated in the factory and does not require to be calibrated on installation. After installation the units should be bump tested. Expose the sensors to test gas using test cylinder (appropriate to the installation) or if not available, crack open the valve of a cigarette lighter (only for Semiconductor units) without igniting it and hold it over the vent holes on the upper right side of the sensor. The gas is heavier than air and should fall into the sensor. This will put the system into alarm. The red LED will light showing the system is in alarm. The delay will prevent the siren sounding or relay switching for the preset delay, if delay is set.

With a bump test you can see the functions of the sensor - the yellow/red led will light, the relay and sounder will function.

To test the siren and or relay function, check the delay is set at zero using the header as shown on the installation diagram and expose to gas as above.

After the gas has cleared, press the reset button.

Before testing the sensors on site the unit must have been powered up and allowed to stabilize.

6- Sensor - Annual Test

To comply with the requirements of EN378 and the F GAS regulation sensors must be tested annually. However local regulations may specify the nature and frequency of this test. If not the recommended procedure should be followed.

Contact us for details.



Check local regulations on calibration or testing requirements.

After exposure to a substantial gas leak, sensor should be checked and replaced if necessary.

7- Check/Calibration Procedure

These units must be checked/tested and/or calibrated by a suitably qualified technician who must test or calibrate the unit in accordance with the instructions as provided or set out in the relevant manual and the standards set down in their particular industry/country. Suitably qualified operators of the unit should be aware of the regulations and standards set down by their industry/country for the testing or calibration of this unit. These notes are only intended as a guide and insofar as permitted by law the manufacturer accepts no responsibility for the calibration and testing or operation of this unit.

Failure to test or calibrate the unit in accordance with the then applicable instructions and with industry guidelines may result in serious injury including death and the manufacturer is not liable for any loss injury or damage arising from improper testing or calibration or inappropriate use of the unit.

The testing or calibration of the unit must be carried out by a suitably qualified technician, in accordance with the testing or calibration instructions and in compliance with locally applicable guidelines and regulations.

INTRODUCTION

The frequency and nature of testing or calibration may be determined by local regulation or standards.

EN378 and the FGAS Regulation require an annual check in accordance with the manufacturer's recommendation.

For 2 level systems, we recommend annual checks by resetting units electrically to the factory calibration settings and a bump test and replacement of the sensors with a pre-calibrated certified sensor every three years. The alternative to replacement is an on-site gas calibration. Sensor replacement may be more cost effective, eliminate end of life concerns, and constantly renew the detection system.

If the sensor is exposed to a large leak it should be tested to ensure correct functionality by electrically resetting to the factory calibration settings and carrying out a bump test.

There are two concepts that need to be differentiated: bump test and calibration

Bump Test: This consists of exposing the sensor to a gas. The objective is to establish if the sensor is reacting to the gas and all the sensor outputs are working correctly. A quantified bump test is one where gas of a known concentration is used.

Calibration: This consists of exposing the sensor to a calibration gas setting the "Sensor Standby voltage", the alarm set points "Alarm Threshold Voltages", and checking/adjusting all the outputs, so that they are activated at the specified alarm gas concentrations when exposed to this gas.

It is required by EN378 to record the check results in the Logbook.

Before you carry out the bump test or calibration:

- 1- Advise occupants, plant operators, and supervisors.
- 2- Check if the unit is connected to external systems such as sprinkler systems, plant shut down, external sirens and beacons, ventilation, etc. and disconnect as instructed by the customer.
- 3- For 1 level systems you must deactivate the 3-min alarm delay if selected by moving jumper JP1 to "off" position. For 2 Level systems upon power up there is a delay of 3 minutes before the Green power LED turns on.
- 4- For Bump Test or Calibration, the units should be powered up overnight.
- 5- If a unit has been powered off for a short time, say due to maintenance, it will normalise within a few minutes. If sensors have been in long-term storage or the detectors have been turned off for a long period, normalisation would be much slower. However within 1-2 hours sensors should have dropped below the low alarm level and be operational. You can monitor normalisation progress exactly by monitoring the sensor output, see Table 1, page 5.



2. Electrical reset / bump test (every year)

Electrical reset is based on the calibration information found on the label on the side of the enclosure and is unique to that sensor.

Tools required:

- 1- A voltmeter– crocodile clips recommended
- 2- Factory set point electric values as shown on the rating label
- 3- Estimate 10 min per sensor

Reset, if necessary, the Standby and low /high Alarm Threshold Voltages to the factory settings as shown on the calibration label. This is performed on the sensor PCB.

For Standby voltage, connect your DC voltmeter between TP5 (0V) and TP4 (+V) as shown in Diagram 2 and adjusting pot RV1.

For low-level alarm voltage, connect your DC voltmeter between TP5 (0V) and TP2 (+V) as shown in Diagram 2 and adjusting pot P8.

For high-level alarm voltage, connect your DC voltmeter between TP5 (0V) and TP1 (+V) as shown in Diagram 2 and adjusting pot P7.

If the factory set point information is not on the calibration label (as with older units) check the serial number of your gas detector on the rating label and sensor PCB and contact us for the appropriate set point values.

3 BUMP TEST

Ideally bump tests are conducted on site in a clean air atmosphere.

3.1 Semiconductor and IR sensors for hydrocarbons: We offer cylinders of calibration gas at known concentration and ampoules for ammonia (NH₃) at 100ppm and 1.000 ppm and using these constitute a quantified bump test.

If Calibration Gas is not available you can carry out a non-quantified bump test using a gas cigarette lighter. By cracking the valve open without igniting the gas, you release the gas onto the sensor and force it into alarm. Check that alarm lights and relays are activated

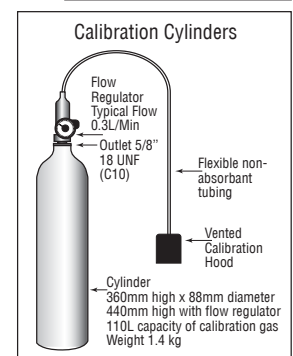



3.2 Bump test using gas ampoules:

- 1- Make sure that both the ampoules and the calibration beaker are clean and dry.
- 2- Unscrew the beaker hold screw and place the ampoule so that it sits in the base of the beaker. As per illustration.
- 3- Tighten on the screw ampoule without breaking it.
- 4- Remove the enclosure lid of the gas sensor (not in Ex area and in one level units as monitoring of voltage can be done on controller).
- 5- Connect volt meter for 1 level unit. On the channel undertest between Pin 4 and Pin2 and for 2 level semiconductor between TP5 and TP4. For IR boards between OV and VS to monitor sensor response
- 6- Place the beaker over the sensor head (using an adaptor if required) or, if an Exd or Remote sensor head version, M35 or M42 thread, screw the beaker on the remote sensor head. It should be as tight a fitting as possible to allow maximum exposure to the gas.
- 7- Tighten on the ampoule until it shatters allowing the content to diffuse in the beaker. It should be left in place for approximately 5 min.
- 8- Voltage output will increase. This confirms that the sensor is responding. In the case of ampoules a response equivalent to 50% or greater of the ampoule concentration will be satisfactory.
- 9- Carefully remove any ampoule remains from the gas detector.

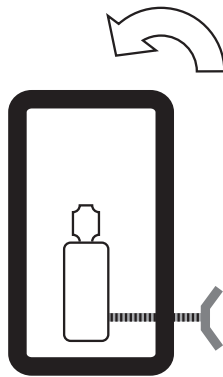

3.3 Bump Test Using Gas Cylinders.

Remove the enclosure lid of the gas sensor (not in an Ex area) and controller (non applicable to Exd Remote sensor and vent pipe model, 1L units as monitoring of voltage can be done on controller).

Connect the voltmeter for 1 level unit. On the channel undertest between Pin 4 and Pin2 and for 2 level semiconductor between TP5 and TP4. For IR boards between OV and VS to monitor sensor response.

Expose the sensor to gas from the cylinder. You can place the entire sensor into a plastic bag or use a plastic hose/hood to direct gas to the sensor head.

4 CALIBRATION (every three years)

The alternatives we describe are:

4.1 Exchanging the sensor board – available for 2 level units and 1+2 level IR units.

4.2 Gas Calibration

4.1 EXCHANGE SENSOR BOARD – available for 2 alarm level system and 1+2 level IR units (every 3 years)

We recommend exchanging your sensor PCB for a newly pre-calibrated certified unit every 3 years.

Tools required:

- 1- A pre-calibrated sensor board
- 2- A voltmeter – crocodile clips recommended
- 3- Estimate 10 min per sensor

In this case you need to:

- 1- Power off the unit and remove lid of sensor enclosure.
- 2- Note the colour code of the cable in positions 1,2,3, and 4 of the connector block.
- 3- Undo the cable and 2 screws securing sensor board and remove.
- 4- Fit the new pre-calibrated sensor and reconnect the cable in the correct colour sequence at positions 1,2,3 and 4.
- 5- Power on the unit and allow to stabilise for 15 min.
- 6- Check voltage readings on positions 1,2,3, and 4 as per procedure in Table 1, page 5, to ensure that wiring is correct. Note also in the table how to monitor the sensor as it normalises.
- 7- Carry out a bump test to confirm the sensor is responding.
- 8- Keep records of the test date, sensor serial number, and any observation.

There are a number of advantages to sensor exchange. It is simpler and quicker than gas calibration. We guarantee the correct calibration and functioning of the new sensor, which is supplied with a calibration certificate and finally, you won't face any problems of sensor deterioration or end-of-life.

4.2 GAS CALIBRATION

This is the adjustment of the gas detector using calibration gas.

We offer a calibration kit that consists of a Calibration gas cylinder and a flow regulation valve with flexible non-absorbant tubing and vented calibration hood.

In some cases this option may be expensive relative to sensor exchange because of the cost of visiting a site, calibration gas and valve, and a surcharge on the freight cost of the calibration gas as it is classified as a hazardous substance (ampoules are not classed as hazardous).

The procedure involves electrical set-up followed by adjustment using calibration gases.

Equipment required:

- 1- Gas cylinders with the appropriate calibration gas concentrations
- 2- Gas canister with zero air to calibrate /check the Sensor Standby Voltage, required if the sensor environment is not clean.
- 3- Flow gas valve – rate 0.3L/min
- 4- A voltmeter
- 5- Estimate 30 min per sensor

The procedure differs slightly depending on the number of alarm levels.

4.2.2 Gas Calibration TWO ALARM LEVELS UNITS

The delay on a 2L system is approximately 25 seconds and cannot be deactivated.

All adjustments are performed on the sensor PCB and there are three elements to be adjusted: the Standby Voltage and two Alarm Thresholds.

a. Sensor Standby Voltage (SSV)

The factory settings are shown on the calibration label on the side of the enclosure.

Connect the voltmeter between TP5 (0V) & TP4 (+Ve) and adjust pot RV1 for 0.3V (on IR units SSV is fixed).

This value should be already set correctly unless age or background has caused drift.

b. Alarm Threshold Voltage (ATV)

Low Threshold:

Connect voltmeter between TP5 (0V) & TP2 (+Ve)/0V and low for IR units, set the voltage as shown on the calibration label by adjusting pot "P8".

High Threshold:

Connect voltmeter between TP5 (0V) & TP1 (+Ve)/0V and high for IR units, set the voltage as shown on the calibration label by adjusting pot "P7".

Remember there is an inbuilt delay response to an alarm of approx. 25 sec on both alarm levels.

Monitor voltage between TP5 (0V) & TP4 (+Ve)/0V and VS on IR units. Apply the low concentration calibration gas to the sensor and wait until the sensor output signal stabilises. Record this voltage. Apply the high concentration calibration gas to the sensor and wait until the sensor output signal stabilises. Record this voltage.

If the voltages recorded for the low and high alarms differ from the factory settings shown on the calibration label then adjust P8 and P7 as above to the new values. Record and use these new values for subsequent electrical set-ups.

The High threshold voltage must be set higher than the low XXX?

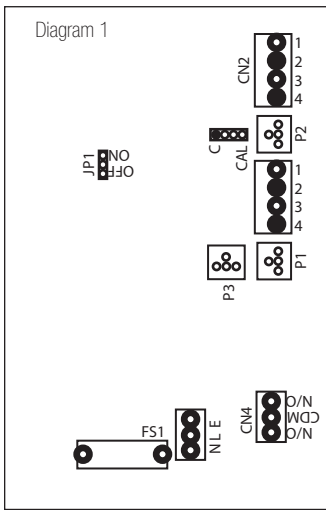

MGD 1 or 2 channel unit.

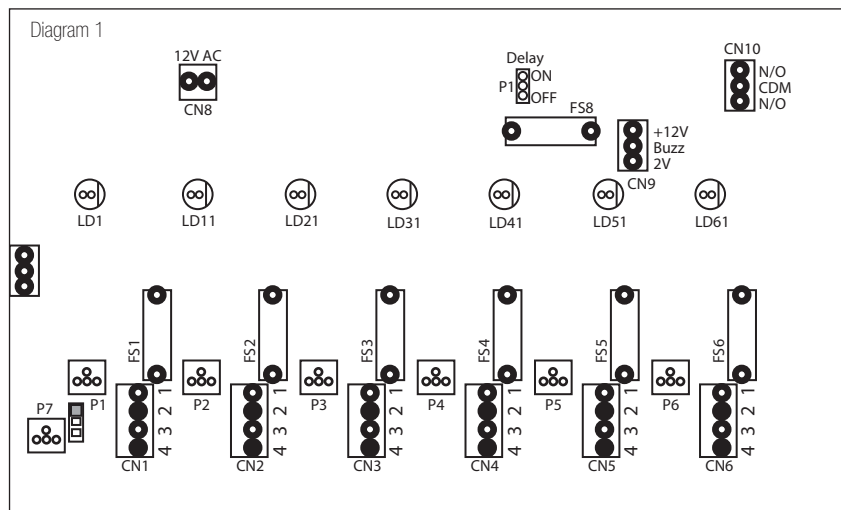

MGD 4 or 6 channel unit.

Diagram 2: Two Level Sensor

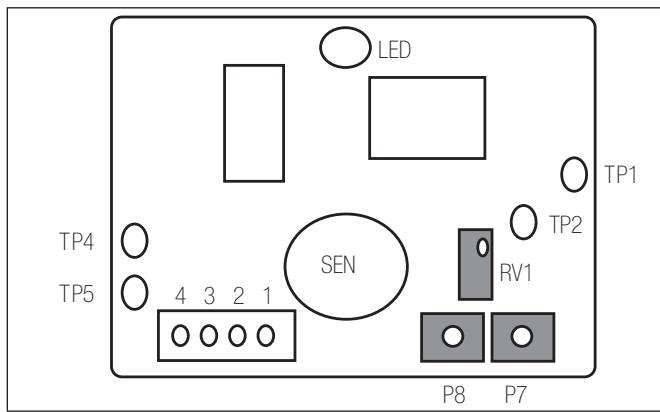

Two Level Systems

You should adjust the relevant alarm threshold upwards in 0.2Volt increments until the condition clears.

5.2 DOUBLE CHECK CONNECTIONS ARE CORRECT:

To make sure the gas detectors are wired up correctly you can check the voltages at the sensor cable terminal blocks on the controller PCB or sensor PCB using a 0-10V voltmeter as outlined below in Table 1.

Place the negative probe on terminal position 4 and with the positive on 1, 3, 2, check the Volts values. The readings are lower at the sensor due to power drop in the line.

The terminals should have the under listed values:



threshold, or the unit will not function correctly.
threshold, or the unit will not function correctly.

5- ADDITIONAL RECOMMENDATIONS

5.1 FALSE ALARMS: If false alarms are being triggered by background gases, paint fumes, etc, or extreme humidity or temperature conditions, you may adjust the settings to compensate.

Table 1. Connections correct values

Position Number	At the Sensor	Controller	Without Sensor Fitted
4	Is the negative side of the power supply	Negative	Negative
1	Power Supply 7.2V minimum reading, unless you have power drop reduction.	+10V	+12-15V
3	Approximately 4-5V	+4.8-5V	+5V
2	Two level system - typical Internal reference values, approximately	+0.4V +1.6V +2.8V	Sensor in standby Low Alarm Condition High Alarm Condition

* The voltage signal from the sensor will on power up start high and gradually fall (in clean air) to the SSV value shown on the calibration label. IR unit will display 0Volts until the 2 minute warm-up has finished.

You can monitor this as follows:

2 level systems: Connect voltmeter and monitor voltage between TP5 (0V) & TP4 (+Ve). For IR monitor between 0V and VS.

8 - Troubleshooting

Alarm Panel:

Symptom: No lights displayed on panel.

Cause:

1. Power failure (check supply)
2. Tripped circuit breaker or blown fuse on electrical supply
2. Blown fuse at the electrical supply on the controller PCB board.
3. Has unit warmed up? (This takes 3-4 minutes after power is switched on.)

Symptom: Red Light is on, but no alarm condition is active. i.e No siren and no relay operation after 3 minutes.

Cause:

1. Make sure the siren has not been deactivated (Key switch).
2. This indicates a wiring or sensor fault (call service provider).
If these are in order the calibration pot may have been adjusted and may need to be reset. Check with us for instructions.

Sensor:

Symptom: Green light on sensor is off.

Cause: This may indicate a wiring fault between the controller and sensor or a sensor fault. Check power supply to the controller. Check connections between the controller and the sensor to ensure that the wires from positions 1 to 4 on the sensor are connected to the corresponding 1-4 on the controller. (See "Wiring Remote Sensors).

On a 4 to 6 channel unit check that the sensor fuse on the particular sensor connection position in the controller is not blown.

If the fault is not cleared then the sensor has been damaged.

If you experience spurious alarms in the absence of a leak, contact us for instructions and support.

9- Installation and Wiring Diagrams

1, 2 Sensor 2 Level Installation Diagram

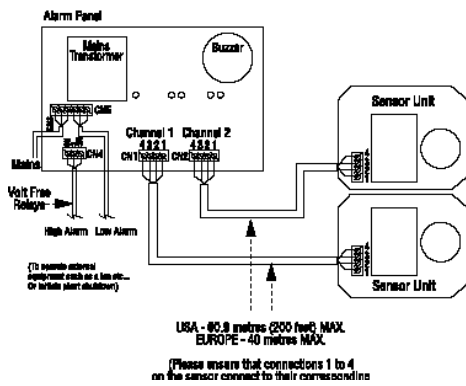

4, 6 Sensor 2 Level Installation Diagram

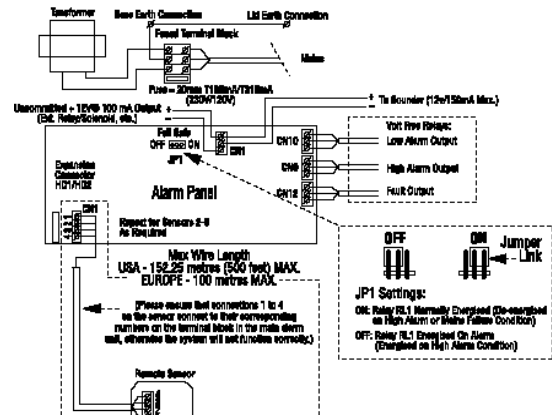

10 - Mounting Diagrams

Standard Sensor

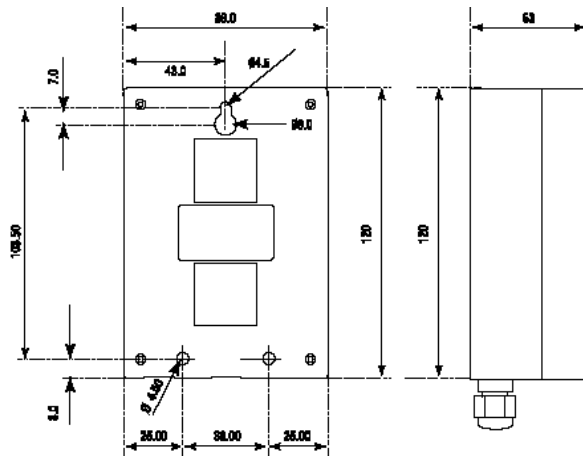

4,6 Sensor Controller Enclosure Relay Expander Box

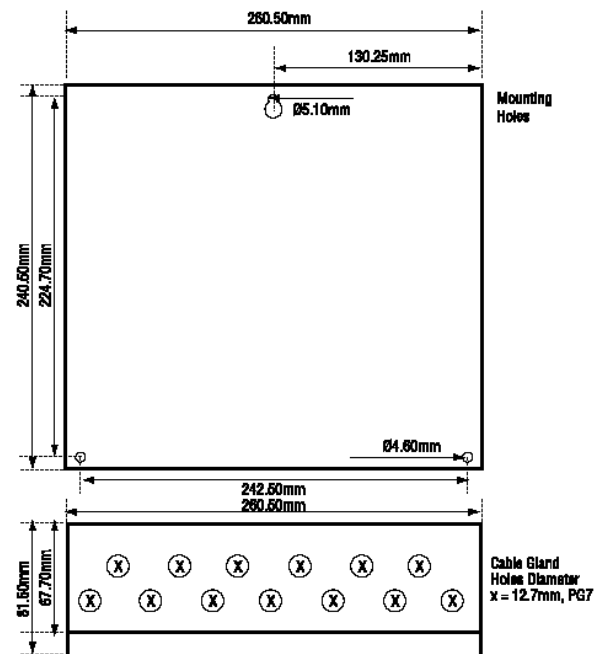

1,2 Sensor Controller Enclosure

