

RecoverXLT™ Oil-Less Universal Refrigerant Recovery Systems

Operation and Maintenance Manual Addendum (Model 95765)

This addendum is for issues relating specifically to *RecoverXLT* Model **95765**. Please refer to the *RecoverXLT* Oil-Less Universal

Refrigerant Recovery Systems Operation and Maintenance Manual for complete operating instructions.

Part#	Description	Part#	Description
95274	Oil-less Compressor 110V, 50Hz	95187	Compressor Relay, 115V
95157	Circuit Breaker - 15 AMP	95433	CPR Valve
95262	Power Cord, European	95523	Transformer

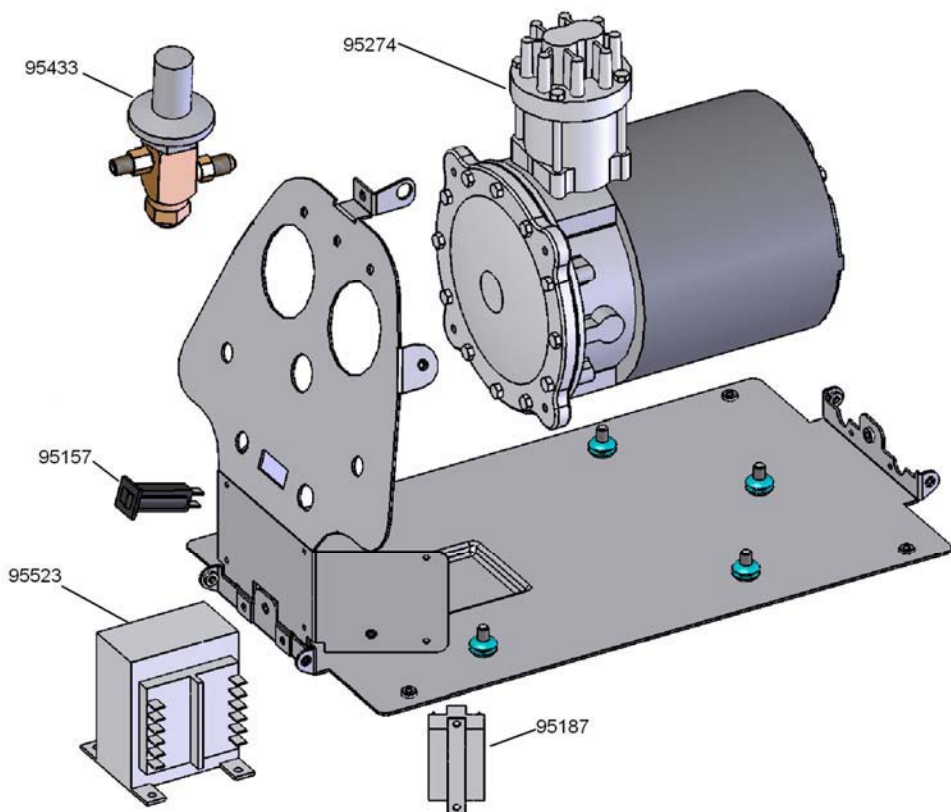

Wiring Diagrams

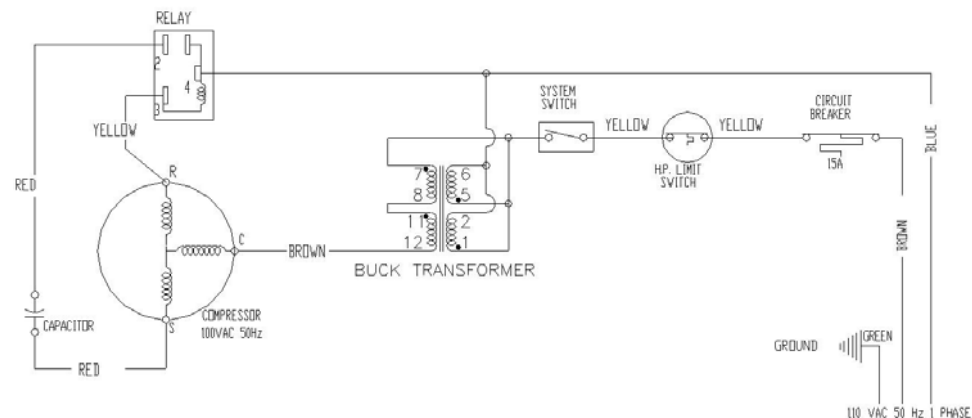

Technical Data

Compressor:	1/2 HP Reciprocating Oil-Less
Power Source:	110V AC 50 Hz 1 Phase
Amperage:	Run Load
Amps:	6.8
	Full Load Amps:
	36.0
	Locked Rotor Amps:
	7.6
Size:	
Height:	12.50" (317.5mm)
Width:	12.50" (317.5mm)
Depth:	19.25" (489mm)
Weight:	38.00 lbs. (17.24 kg)

FOR PROFESSIONAL USE ONLY



MADE IN U.S.A.
Bloomington, MN